

SPINNING BLADES

The propeller attached to the top of a helicopter is called a rotor. In this activity you will compare the thrust forces produced by different propellers and investigate how blade angle affects a rotor's performance.

WHAT YOU'LL NEED

- A rotor unit with propeller attached
- Two or more other propellers of a different design
- A top-pan balance
- Masking tape
- Scissors
- A felt-tipped pen or marker
- Two or more discs of thick aluminium foil
- A rotor adapter

PROPELLER

A propeller is a device that has two or more blades connected to a hub. When a propeller is connected to a motor it spins to create a force called thrust that allows an aircraft to move through the air.

ROTOR

The propeller mounted on top of a helicopter is called a rotor. The rotor pushes air downwards to create an upward thrust.

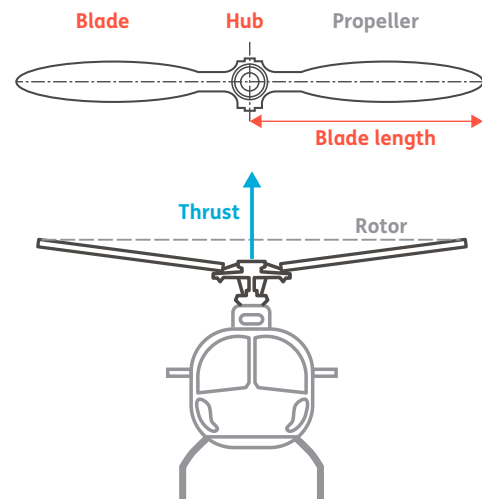

WHAT YOU NEED TO DO

1. Work with your partner to set up your testing station

- Switch on the top pan balance and wait for it to settle. Make sure that the balance reads zero and that it is measuring in grammes (g).
- Place your rotor unit on the balance and switch on the propeller. You will notice that the rotor unit tries to rotate. Prevent this motion by using a loop of masking tape on the bottom of the rotor unit.
- The propeller pushes air downwards towards the top pan balance. If the air hits the balance it will affect the accuracy of your reading. Can you think of a way of reducing the amount of air hitting the balance?

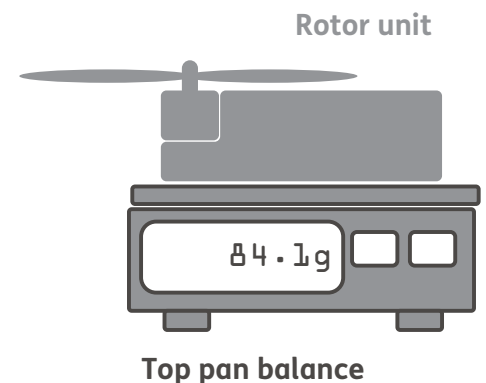

SPINNING BLADES

2. Investigate the thrust produced by each of the plastic propellers

- Copy the table.
- Count the number of blades and measure blade length for the propeller on the rotor unit. Record these values in the first row of your table.
- Place the rotor unit on your on the balance and take readings with the propeller on and off. Record both of these in the table.
- Work out the difference in the two readings.
- Now change to a different propeller. Follow the same steps as you did with the first propeller and record the results in the table.

- Repeat for each propeller. Which propeller gives the greatest thrust?
- The number of blades and/or blade length for each propeller is different. What other differences are there between the propellers?

Blade		Reading on balance		
Number	Length	Motor off	Motor on	Difference

3. Make an aluminium propeller and investigate how blade angle affects thrust

- You have been provided with some thin circular discs of aluminium with small holes through their centres. On one of the discs draw the pattern shown below and cross out the bits you will cut off to make the two-bladed shape shown.
- Cut along the lines to make your blades. Do not cut into the central circle.
- The blades will rotate anticlockwise when you connect them to the motor. Draw arrows to show the direction of rotation.
- You have been provided with rotor adaptor. Remove the dome of the adaptor. Push the propeller onto the top of the adaptor and the bottom of the adaptor onto the rotor unit. Screw the dome down onto the aluminium to hold it everything firmly in place

- Use the top pan balance to find how much thrust the flat blades produce.
- The leading edge of your blades is the edge that hits the air first when the blades spin. To make an upward thrust force, the leading edge of a blade has to point upwards. Twist the blades so that both of the leading edges (tip of arrows) face upwards and trailing edges (tail of arrow) point downwards.
- Use a protractor to set the blade angles to 10° . Take readings using the top pan balance with the rotor off and on.
- Increase blade angle from 0 to 70° , at 10° intervals, and take readings to investigate how thrust varies with blade angle. Which angle produces the most thrust?
- Design your own aluminium propeller and make it. Can you get more thrust than the two-bladed design?

